

Power Wave[®] S500

Processes

Stick, DC TIG, Pulsed DC TIG, MIG, Pulsed MIG, Flux-Cored

Product Number

K2904-1 Power Wave[®] S500
K3187-1 Power Wave[®] S500 Ready-Pak[®]
K3186-1 Power Wave[®] S500 One-Pak[®]

See back for complete specs

Input Voltage

200/208/220/230/380/400/415/460/575/
3/50/60

Input Current @ Rated Output

3 Ph / 40% Duty Cycle: 80/73/41/37/29A
3 Ph / 100% Duty Cycle: 60/54/30/27/21 A

Output Range

5 - 550 Amps

Rated Output

GMAW: 550A/41.5V/40%
GMAW: 450A/36.5V/100%

Weight/Dimensions (H x W x D)

150 lbs. (68 Kg)

22.5 x 14 x 24.8 in.

(571 x 355 x 630 mm)

Powerful Multi-Process Capability.

The multi-process Power Wave[®] S500 is packed with Lincoln Electric performance technology for welding on thicker materials. It provides an extremely fast arc response, includes over 65 standard welding waveforms for optimized performance on almost any application and efficiently converts input power to reduce operational costs.

FEATURES

- ▶ **PowerConnect™ Technology (Patent-Pending)** - Automatically adjusts to input power from 200-600V, 50 or 60 Hz, three phase. Welding output remains constant through the entire input voltage range.
- ▶ **Tribrid™ Power Module** - Exceptional welding performance with high power factor and efficiency.
- ▶ **CheckPoint™ and Production Monitoring™ 2.2** - Use your server or our cloud-based server to view and analyze your welding data on almost any device - desktop, laptop, iPhone[®] or iPad[®], BlackBerry[®] and others. Track equipment usage, store weld data, configure fault limits and more.
- ▶ **Standard 115V (10A) AC Duplex Auxiliary Power Receptacle** - Features patent-pending Surge Blocker™ Technology to ensure simultaneous welding performance is not compromised by high starting current devices such as grinders (typically requiring 60A or more peak surge current).
- ▶ **Durable Case** - IP23 rated to withstand harsh environments.
- ▶ **Standard Ethernet** - Allows for effortless software upgrades through powerwavesoftware.com

APPLICATIONS

- ▶ Construction
- ▶ Aerospace
- ▶ Fabrication
- ▶ Automotive
- ▶ Production



RECOMMENDED WIRE FEEDERS

- ▶ Power Feed[®] 10M bench and boom models
- ▶ Power Feed[®] 25M

WAVEFORM CONTROL TECHNOLOGY[®] PROCESS CAPABILITIES

- ▶ Pulse
- ▶ Pulse-on-Pulse[®]
- ▶ Power Mode[®]
- ▶ RapidArc[®]
- ▶ Rapid X™
- ▶ Upgradable for additional processes to be developed in the future.

INPUT



OUTPUT



Two Year Extended Warranty Available in the U.S.A. and Canada.



KEY CONTROLS

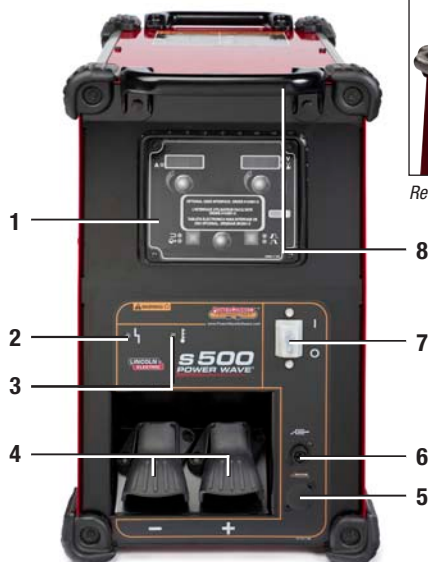

Reversible handles shown

FRONT

1. Optional S-Series User Interface Kit (K3001-2) for Stick, TIG and CV MIG with voltage sensing feeder
2. Status Light
3. Thermal Fault Indicator Light
4. Output Studs
5. Output Control Receptacle Knockout Plate – 12-pin (for optional output control receptacle included with K3001-2 S-Series User Interface Kit)
6. Work Sense Lead Receptacle
7. Main Power Switch
8. Reversible Handles

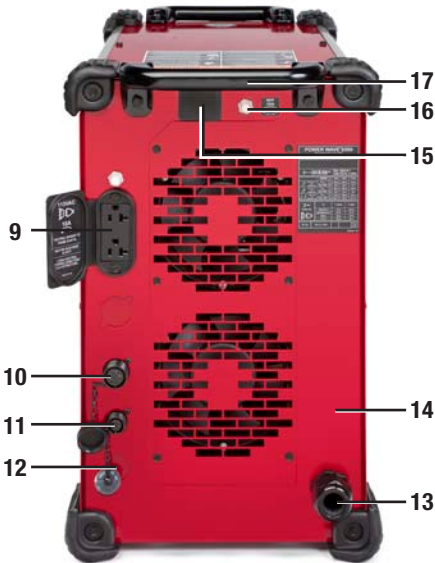

BACK

9. Standard 115V (10 Amp) AC Duplex Auxiliary Power Receptacle and Circuit Breaker
10. ArcLink® Welding System Component Communication Cable Receptacle
11. Sync Tandem/STT® Receptacle
12. Optional DeviceNet™ Kit (K2827-1)
13. Input Power Cable Connection
14. TIG Solenoid Kit Knockout Plate (for optional TIG solenoid included with K3001-2 S-Series User Interface Kit)
15. Ethernet Cable Receptacle
16. Circuit Breaker (ArcLink®)
17. Reversible Handles

OPTIONAL K3001-2 S-SERIES USER INTERFACE KIT

To tap into the Power Wave® S500 stick, TIG and CV MIG process capability without a Power Feed® series wire feeder, add the K3001-2 User Interface Kit. This optional interface provides full control of welding parameters from the front panel of the power source for stick and TIG processes. When used with a Power Feed® series wire feeder, the feeder is typically used for controlling the system and the K3001-2 User Interface Kit meters can be used for viewing amps and volts. Kit also includes 12-pin Universal Remote Receptacle and TIG Gas Solenoid.

The User Interface Kit allows control over:

- **Volts/Amps Control** – Adjust volts in MIG and flux-cored welding or adjust amperage in stick or TIG welding.
- **Advanced Process Options** – Control pre- and post-weld settings to optimize arc starts and stops.
- **Welding Mode** – Select the stick, TIG or CV wire process.
- **Arc Control** – Adjust arc characteristics to match individual preferences.



WHAT'S INCLUDED

Ready-Pak® Packages are assembled and shipped on one pallet. **One-Pak® Packages** are not assembled. All packages can be ordered using a single Product Number (K#). Welding wire and shielding gas must be ordered separately.

Power Wave® S500/Power Feed® 10M Bench Feeder Ready-Pak®, includes:

- Power Wave® S500 (K2904-1)
- Power Feed® 10M Bench Model (K2230-1)
 - Wire Reel Stand
 - ArcLink®/Linc-Net™ Control Cable with Weld Power Cable - 8 ft. (2.4 m)
- Magnum® PRO Curve™ 400 Gun and Cable Package (K2952-2-10-45)
- .040-045 (1.0-1.1 mm) Drive Roll Kit (KP1505-045S)
- Work Lead Package (K2149-1)
- Harris® Flowmeter Regulator and Hose (3100211)
- Inverter and Wire Feeder Cart (K3059-2)

Order K3187-1

Power Wave® S500/Power Feed® 10M Bench Feeder One-Pak®, includes:

- Power Wave® S500 (K2904-1)
- Power Feed® 10M Bench Model (K2230-1)
 - Wire Reel Stand
 - ArcLink®/Linc-Net™ Control Cable with Weld Power Cable - 8 ft. (2.4 m)
- Magnum® PRO Curve™ 400 Gun and Cable Package (K2952-2-10-45)
- .040-045 (1.0-1.1 mm) Drive Roll Kit (KP1505-045S)
- Work Lead Package (K2149-1)
- Harris® Flowmeter Regulator and Hose (3100211)

Order K3186-1



Shown: K3187-1

POWER WAVE® S500 TECHNOLOGIES



Tribrid™ Power Module

Patent-pending Tribrid™ Power Module features Lincoln Electric's PowerConnect™ technology, Planar Transformer™ Technology and 120kHz output to provide exceptional welding performance while still maintaining a high power factor and efficiency.



iARC™ High Speed Digital Controls

iARC™ (Intelligent Architecture for Regulation and Control) digital welding controls are more than 10 times faster than the previous generation, with 128 times more RAM, and 8 times more flash memory. It also features 100Mbps Full Duplex Ethernet to support Lincoln Electric's Production Monitoring™ 2.2.



CheckPoint™ and Production Monitoring™ 2.2

CheckPoint™ cloud server-based and mobile delivery solutions, along with enterprise network-based Production Monitoring™ 2.2, are the welding industry's most advanced weld data collection and monitoring tools, allowing fabricators to analyze their welding operations and processes. These tools can provide necessary data for customer ISO, Six Sigma, statistical process control (SPC), quality cost delivery (QCD), overall equipment effectiveness (OEE) and lean manufacturing efforts. CheckPoint™ Standard Edition is offered at no charge with every Power Wave® purchase. An advanced capability Premium Subscription Edition is also available.



Rugged Reliability

Like all Lincoln Electric welding equipment, the Power Wave® S500 was tested under severe conditions to ensure proper operation in the harshest environments:

- Extreme Temperature Ranges
- Extreme Humidity
- Rain
- Dirt and Dust
- IP23 Rated Performance

RECOMMENDED ACCESSORIES

WIRE FEEDER OPTIONS

STT® Module

This module allows easy connection and fast digital communication with compatible Power Wave® S-Series power sources, Power Feed® wire feeders, and compatible water coolers. Add STT® capability without having to purchase a second power source.
Order K2902-1 US/Int'l (shown)
Order K2921-1 CE



AutoDrive® 19 Controller

Relays wire feed commands from Power Wave® S Series power source to any AutoDrive® Series robotic wire drive for automated welding operation. Not compatible with Power Wave® R-Series power sources.
Order K3004-1



AutoDrive® 19 Tandem Controller

Relays wire feed commands from Power Wave® S-Series power source to any AutoDrive® Series robotic wire drive for automated tandem welding operations.
Order K3171-1



RECOMMENDED ACCESSORIES

GENERAL OPTIONS



S-Series User Interface Kit

This kit allows local control of stick, TIG and wire processes from the power source control panel. Includes TIG Solenoid and Remote Control Connector.
Order K3001-2



DeviceNet™ Kit

The kit allows DeviceNet™ connectivity to control the power source. Includes internal harness and 5-pin DeviceNet™ receptacle for mounting on power source back panel.
Order K2827-1



Inverter and Wire Feeder Cart

Rear-wheeled cart with front casters and gas bottle platform. Convenient handles allow for easy cable storage. Small footprint fits through 30 in. (762 mm) door. Not intended for use with double head wire feeders.
Order K3059-2



Work Lead Package

15 ft. (4.5 m) 4/0 cable with 1/2 in. stud lug and work clamp.
Order K2149-1



Cool Arc® 55

Designed to integrate directly with the Power Wave® S-Series power sources, the Cool Arc® 55 is capable of cooling torches rated up to 500 amps for robotic or hand-held MIG, TIG, and plasma cutting applications. 115/1/60 input voltage.
Order K3086-1



Work Voltage Sense Lead Kit

Required to accurately monitor voltage at the arc.
Order K940-25 for 25 ft. (7.6 m)
Order K1811-50 for 50 ft. (15.2 m)
Order K1811-100 (shown) for 100 ft. (30.5 m)



Deluxe Adjustable Gas Regulator & Hose Kit

Accommodates CO₂, Argon, or Argon-blend gas cylinders. Includes a cylinder pressure gauge, dual scale flow gauge and 4.3 ft. (1.3 m) gas hose.
Order K586-1



Weld Fume Control Solutions

Lincoln Electric offers a wide variety of weld fume control solutions, ranging from portable systems easily wheeled around the shop to shop-wide central systems servicing many dedicated welding stations.
Request Publication MC08-70



STICK OPTIONS

Accessory Kit

Complete kit for stick welding. Includes 30 ft. (9.1 m) electrode cable, 25 ft. (7.6 m) work cable, headshield, work clamp and electrode holder. 150 amps.
Order K704



Accessory Kit

Complete kit for stick welding. Includes 30 ft. (9.1 m) electrode cable, 25 ft. (7.6 m) work cable, headshield, work clamp and electrode holder. 150 amps.
Order K875



Remote Output Control with 12-pin Universal Connector

Permits remote adjustment of output. Requires K3001-2 S-Series User Interface Kit.
Order K857-2 for 25 ft. (7.6 m)



12-pin to 6-pin Adapter

Allows older 6-pin remote controls (K870, K963-3, K857) to be used with 12-pin Universal Connection.
Order K2909-1



12-pin to 7-pin Adapter

Allows 7-pin push-pull guns to be used with 12-pin Universal Connection.
Order K2910-1



TIG OPTIONS

PTA-17 150 Amp Air-Cooled TIG Torch

Order K1782-1 for 12.5 ft. (3.8 m) length, 1-cable
Order K1782-3 for 25 ft. (7.6 m) length, 1-cable



PTA-26 200 Amp Air-Cooled TIG Torch

Order K1783-1 for 12.5 ft. (3.8 m) length, 1-cable
Order K1783-3 for 25 ft. (7.6 m) length, 1-cable



Parts Kits

Magnum® Parts Kits provide all the torch accessories you need to start welding. Parts kits provide collets, collet bodies, a back cap, alumina nozzles and tungstens in a variety of sizes, all packaged in an easy to carry reclosable box.
Order KP508 for PTA-17
Order KP509 for PTA-26



Foot Amptrol™ with 12-pin Universal Connector

Provides 25 ft. (7.6 m) of remote current control for TIG welding. Requires K3001-2 S-Series User Interface Kit.
Order K870-2



Hand Amptrol™ with 12-pin Universal Connector

Provides 25 ft. (7.6 m) of remote current control for TIG welding. Requires K3001-2 S-Series User Interface Kit.
Order K963-4

PRODUCT SPECIFICATIONS

Product Name	Product Number	Input Voltage	Input Current @ Rated Output	Rated Output Current/Voltage/Duty Cycle	Output Range	H x W x D inches (mm)	Net Weight lbs. (kg)
Power Wave® S500	K2904-1	200/208/220/230/380/400/415/460/575/3/50/60	3 Ph / 40% Duty Cycle: 80/73/41/37/29 3 Ph / 100% Duty Cycle: 60/54/30/27/21	GMAW: 550A/41.5V/40% GMAW: 450A/36.5V/100% SMAW: 550A/42V/40% SMAW: 450A/38V/100% GTAW-DC: 550A/32V/40% GTAW-DC: 450A/28V/100%	5-550A	22.5 x 14 x 24.8 (571 x 355 x 630)	150 (68)
Power Wave® S500/ Power Feed® 10M Ready-Pak®	K3187-1						
Power Wave® S500/ Power Feed® 10M One-Pak®	K3186-1						

For best welding results with Lincoln Electric equipment, always use Lincoln Electric consumables. Visit www.lincolnelectric.com for more details.

CUSTOMER ASSISTANCE POLICY

The business of The Lincoln Electric Company is manufacturing and selling high quality welding equipment, consumables, and cutting equipment. Our challenge is to meet the needs of our customers and to exceed their expectations. On occasion, purchasers may ask Lincoln Electric for information or advice about their use of our products. Our employees respond to inquiries to the best of their ability based on information provided to them by the customers and the knowledge they may have concerning the application. Our employees, however, are not in a position to verify the information provided or to evaluate the engineering requirements for the particular weldment. Accordingly, Lincoln Electric does not warrant or guarantee or assume any liability with respect to such information or advice. Moreover, the provision of such information or advice does not create, expand, or alter any warranty on our products. Any express or implied warranty that might arise from the information or advice, including any implied warranty of merchantability or any warranty of fitness for any customers' particular purpose is specifically disclaimed.

Lincoln Electric is a responsive manufacturer, but the selection and use of specific products sold by Lincoln Electric is solely within the control of, and remains the sole responsibility of the customer. Many variables beyond the control of Lincoln Electric affect the results obtained in applying these types of fabrication methods and service requirements.

Subject to Change – This information is accurate to the best of our knowledge at the time of printing. Please refer to www.lincolnelectric.com for any updated information.

LINCOLN
ELECTRIC
THE WELDING EXPERTS®